

Measuring Axles

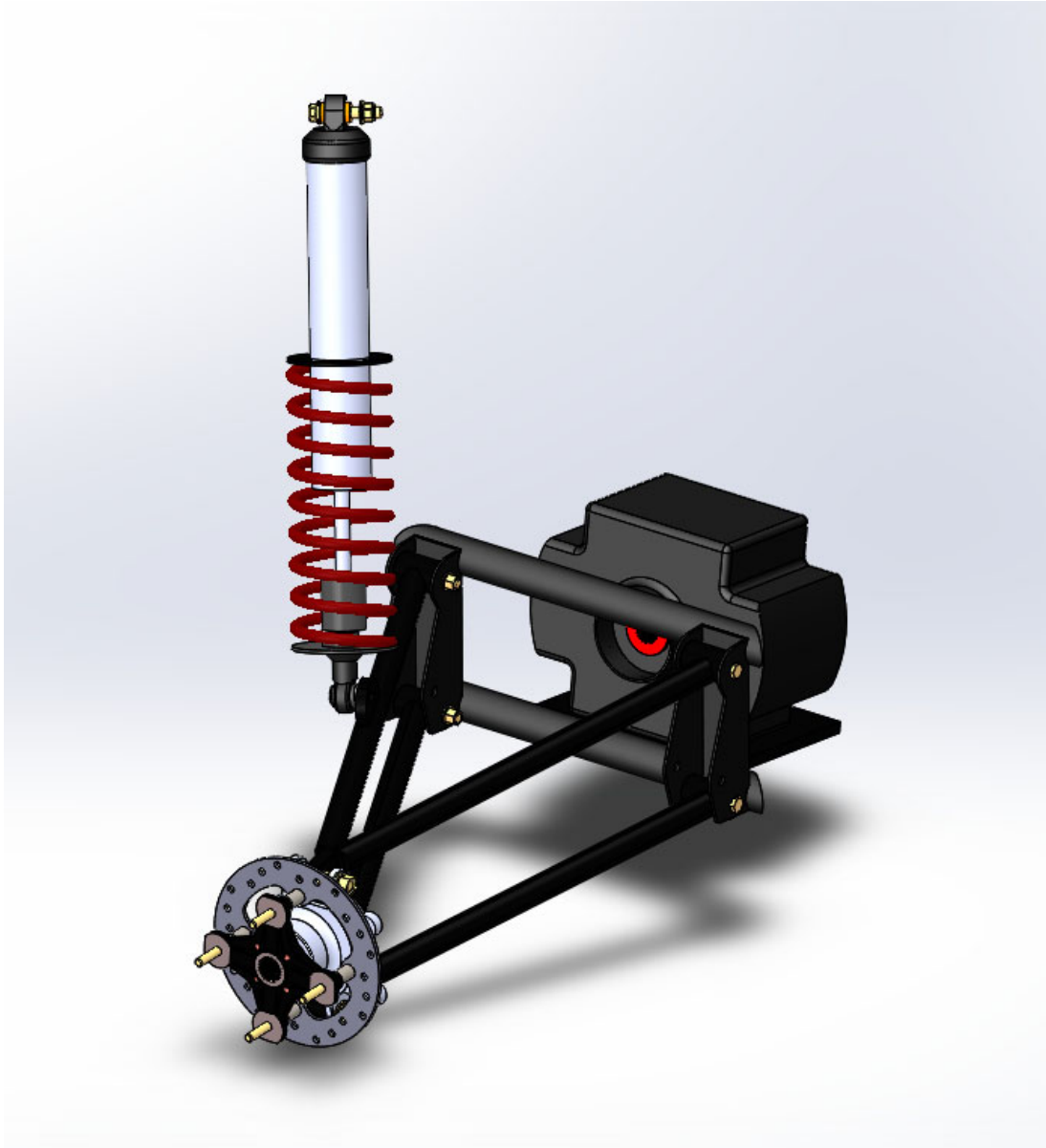

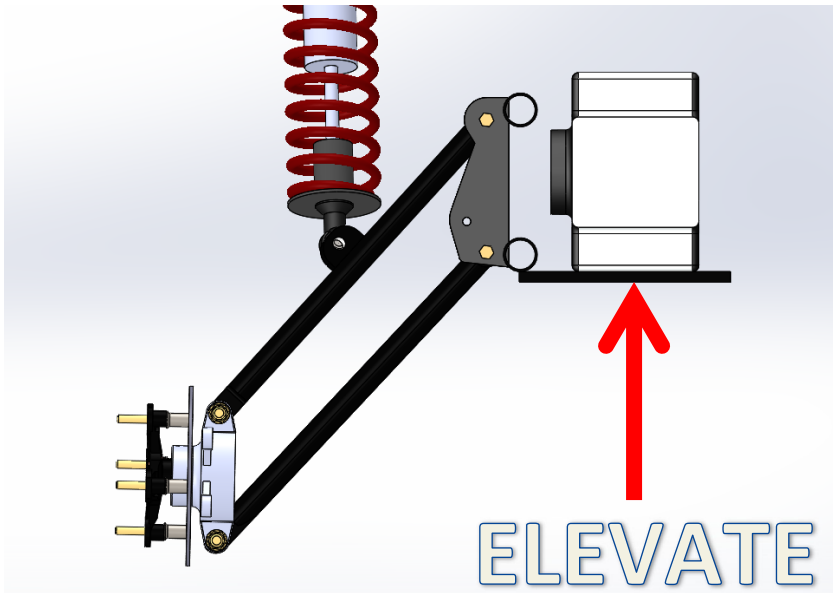

STEP ONE: First thing that needs to be done is to get the end you are measuring elevated. This gets you to the largest angle and distance your vehicle will need when in operation.

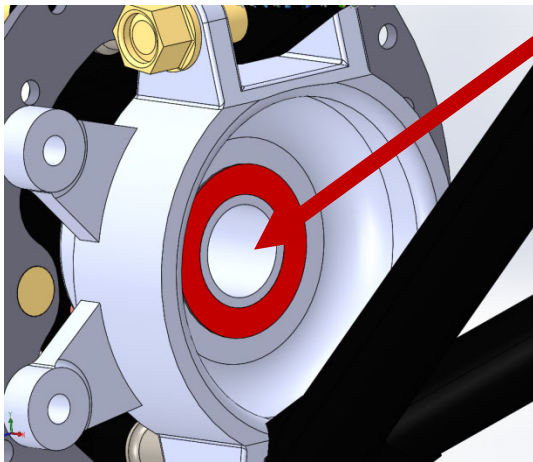
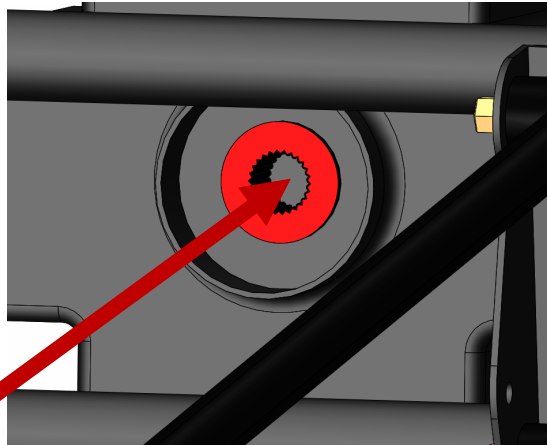

STEP TWO: Once you have the item elevated and the old axle is removed you need to get a measurement from the face of the differential to the inner face of the wheel hub.

(Illustrated in red in the photos)

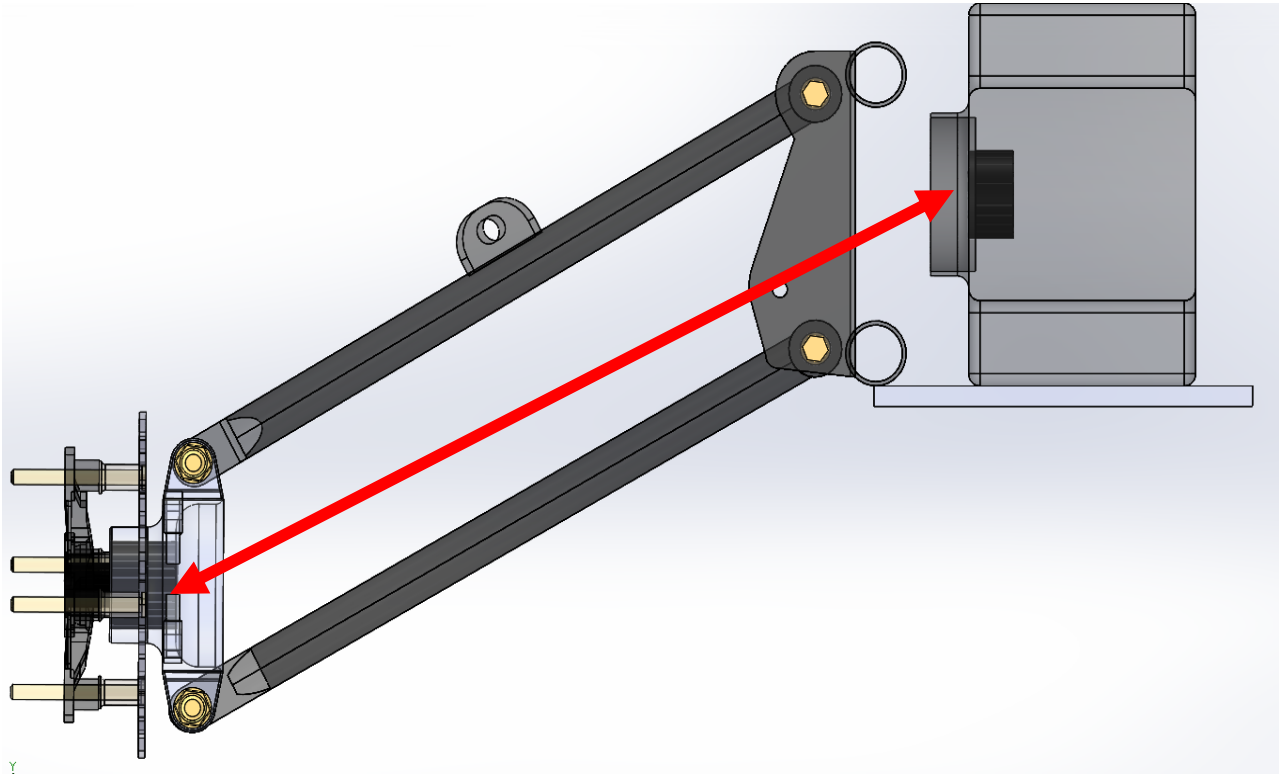

STEP THREE: Once you have taken the measurement you need as indicated by the RED line you have successfully measured that axle at full droop. You can then lower the vehicle back to the ground to take measurements for the compressed level.

(Most vehicles run the same length on each side of a vehicle but it never hurts to measure both sides just in case your vehicle is an exception)

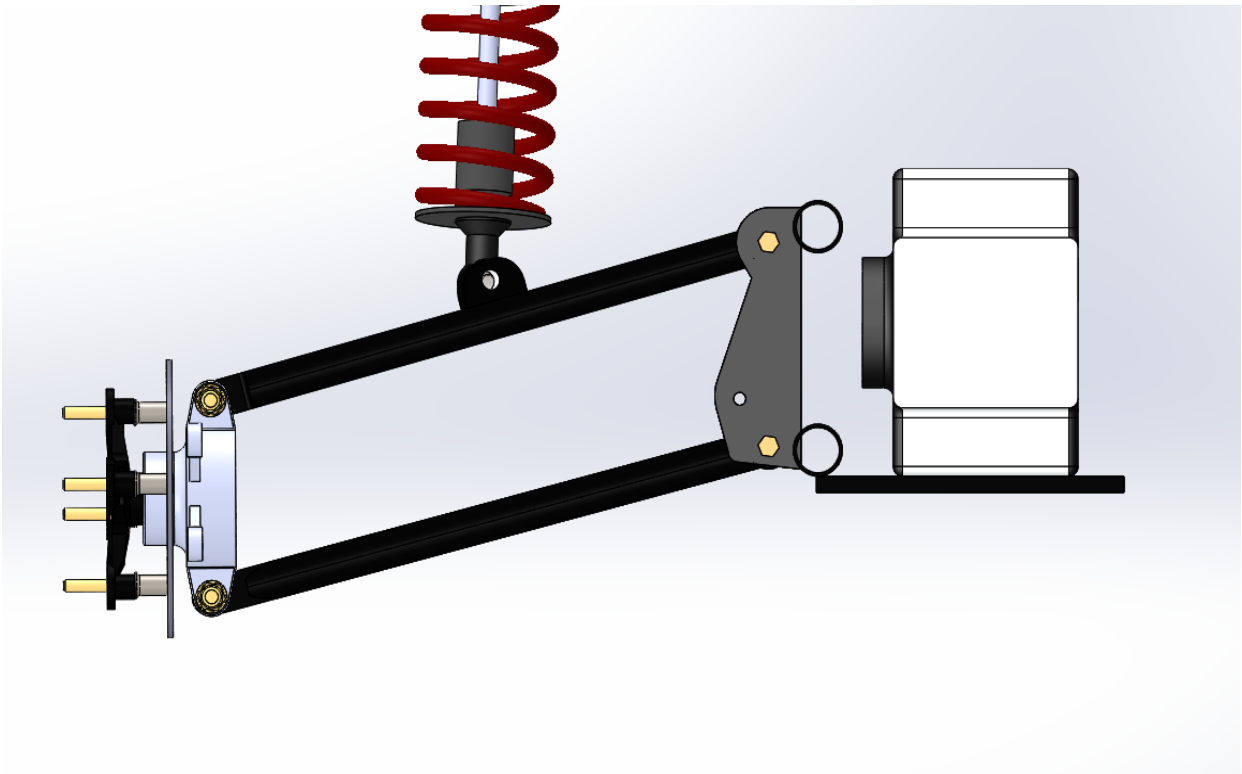

STEP FOUR: Once the vehicle is back on the ground you will need to take the same measurements. The reason being to get your compressed length. This is necessary to give your vehicle the best functionality at performance.

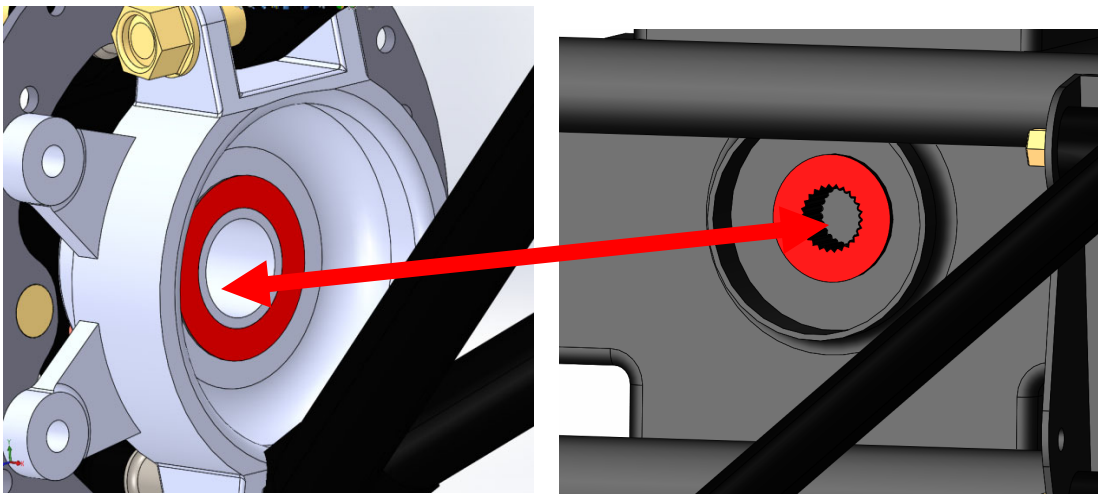

AXLE SHEET

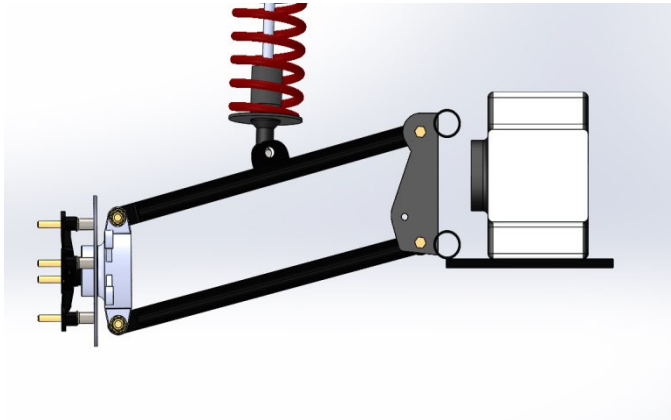

COMPRESSED MEASUREMENT

(INSIDE WHEEL HUB TO DIFFERENTIAL)

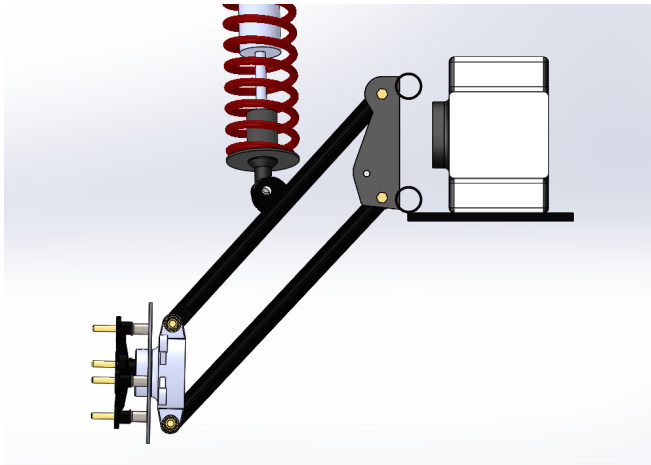

FULL DROOP MEASUREMENT

(INSIDE WHEEL HUB TO DIFFERENTIAL)

VEHICLES MAKE: _____

VEHICLES MODLE: _____

LIFT KIT SIZE (inches): _____

(Fill out the sheet and fax to: (815) 965-4857)